

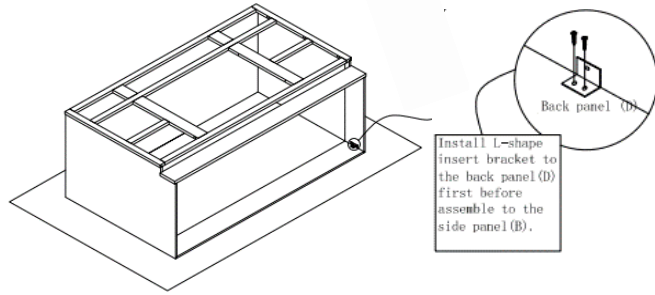

(Item: V48-6)

Step 7 : Install back panel. Fit in the L-shape insert bracket from back panel (D) into side panel (B) bracket and assembly the bracket with (1)  $\Phi 3.5 \times 12$ mm screw.



Step 8 : Install corner block. Install rainbow bracket to the side panel (B), front frame (A) and back panel (D) with the (5)  $\Phi 4 \times 16$ mm screw.

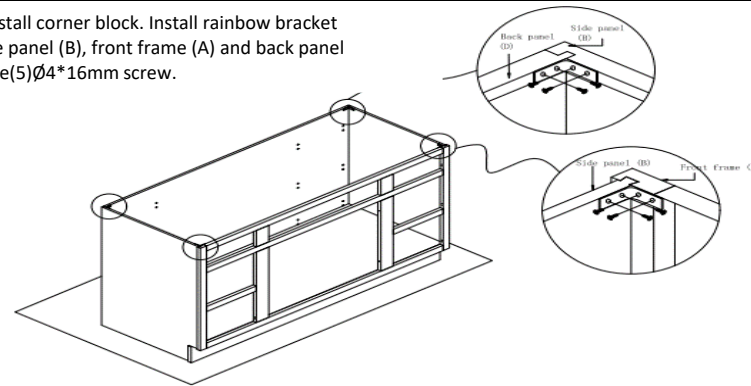

Step 9 : Install the drawer slide rear bracket. Screw the rear slide bracket to the back panel (D)

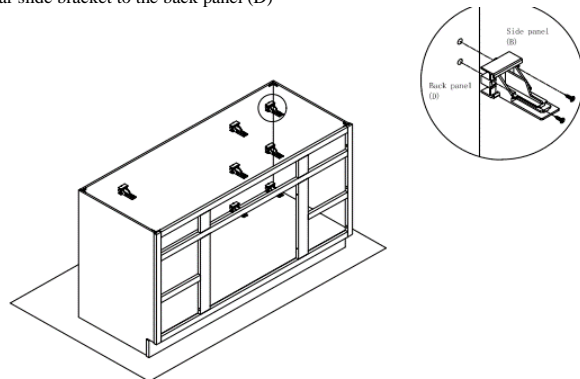

Step 10 : Insert drawer slide runner to the rear slide bracket and screw the drawer slide to the guide hole of front frame (A) and hole for drawer slide.

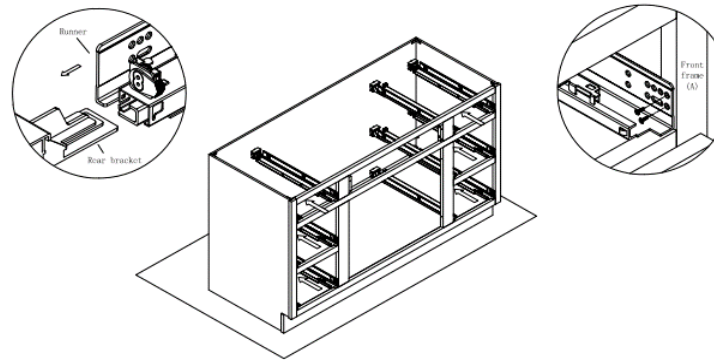

Step 11 : Put the drawer box on the drawer slide and push the drawer box to make the end of runner is lock to the hole of the drawer back panel. Complete the installation of the drawer box when you hear sound click which mean the locking device is locked on the drawer slide.

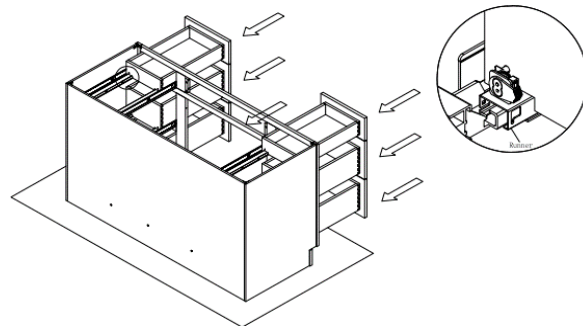

Step 12 : Install door panel (G). Screw the hinge to the front frame (A) and door (G).

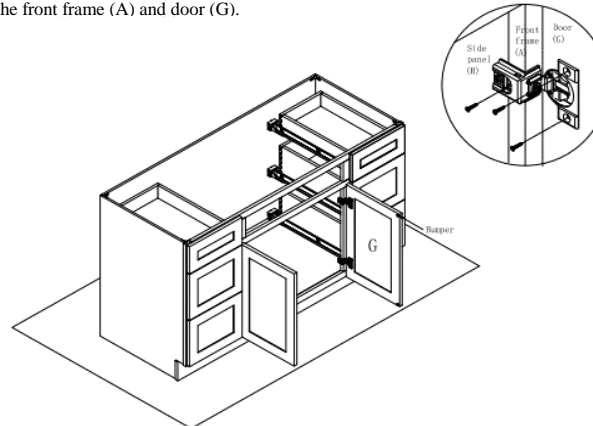

Step 16 : Finish installation of the cabinet

